



Optically Addressed SLM Incorporating a $\text{CuInGaSe}_2/\text{a-Si:H}$ Heterojunction

Blake Eliasson & Garret Moddel
Department of Electrical and Computer Engineering
University of Colorado at Boulder



Design & Fabrication Issues

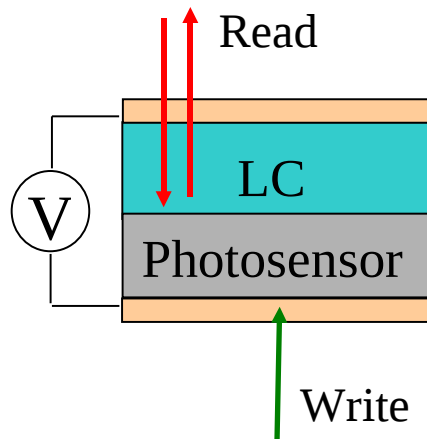

- Flatness of photosensor
 - InGaAs
 - CuInGaSe_2
- Graded phase at kHz frame rates
 - FLC
 - NLC
- Resolution (40 lp/mm)
 - a-Si:H
- Dark current (1 mA/cm²)
 - p-n heterojunction

OASLM Structure

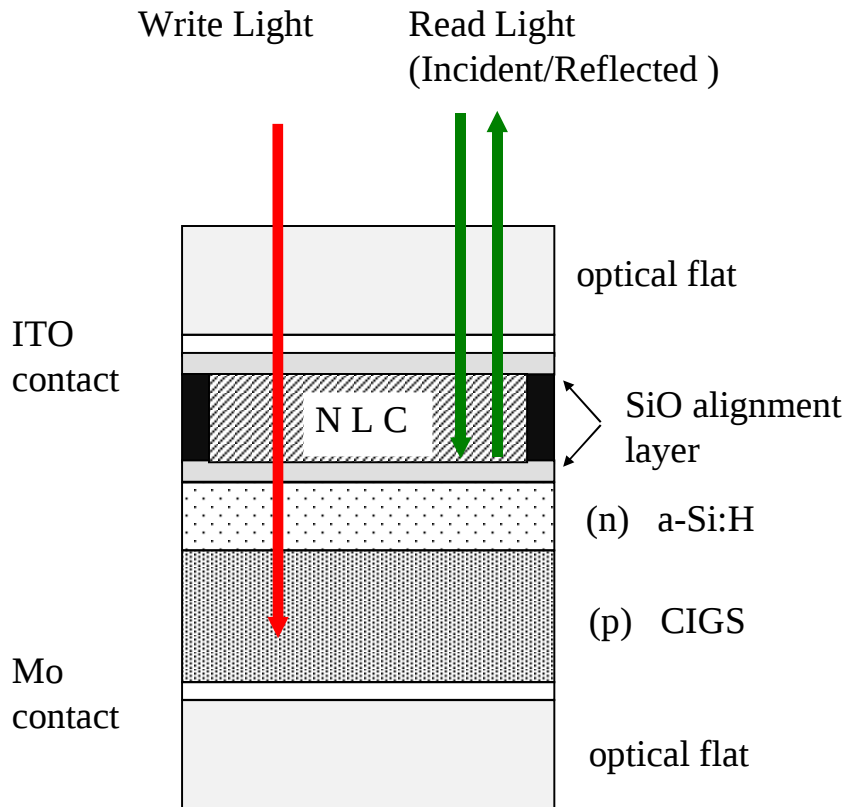

- Read light : 514 nm
- Write light : 935 nm
- Nematic Liquid Crystal
 - EM Industries E44
 - 2 um thick spacers
- a-Si:H
 - 400 nm thick (n++)
- CIGS
 - 2.5 um thick (p-type)

Band Discontinuities

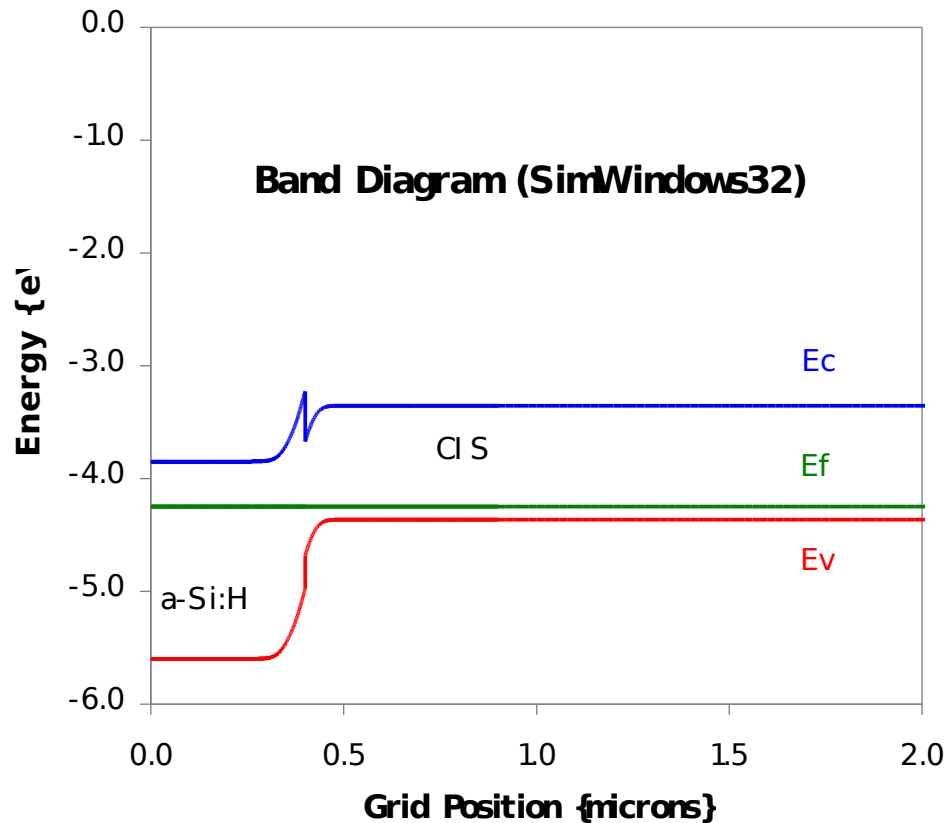

- Ideal electron affinities
- Discontinuity
 - trap photo-generated carriers
 - material grading
 - surface states



Experimental I(V) Curve

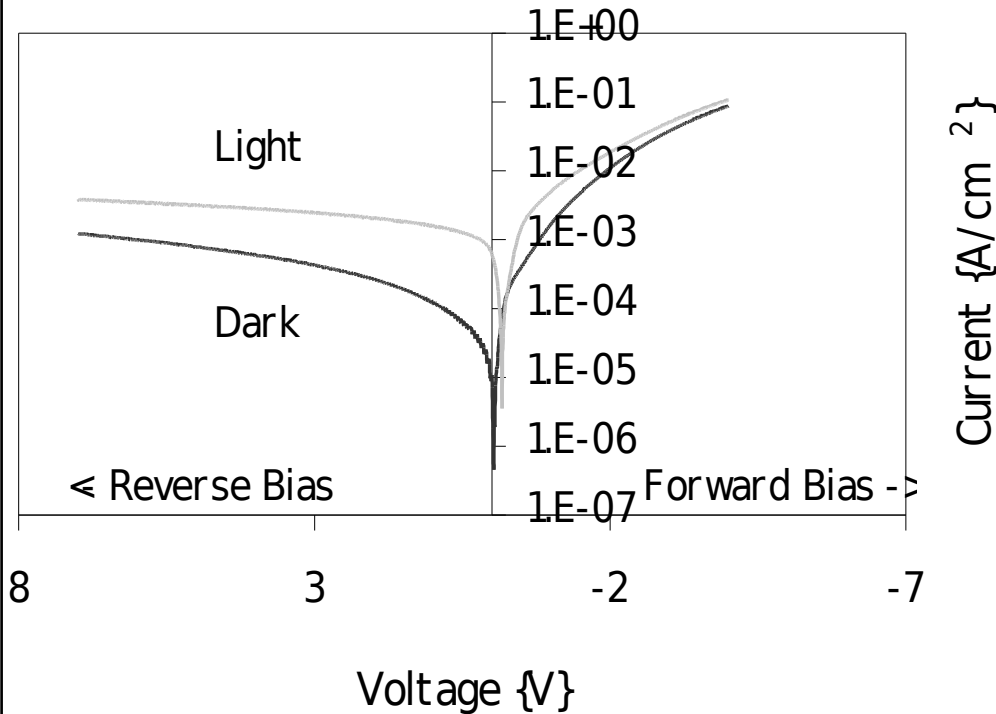

- Suitable rectification
- Response to white light
- Reverse breakdown beyond operating range
- Dark current < 1 mA/cm²





Collection Efficiency

External Quantum Efficiency

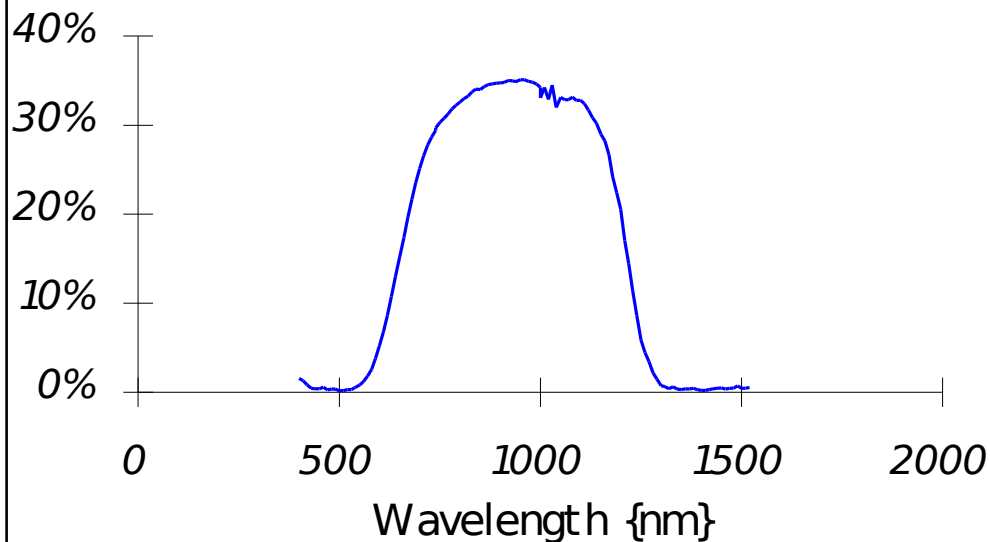

- near 100% internal quantum efficiency
- Bandgap ~ 1 eV
- Write light: 935 nm
- Read light: 514 nm





OASLM Test Bed

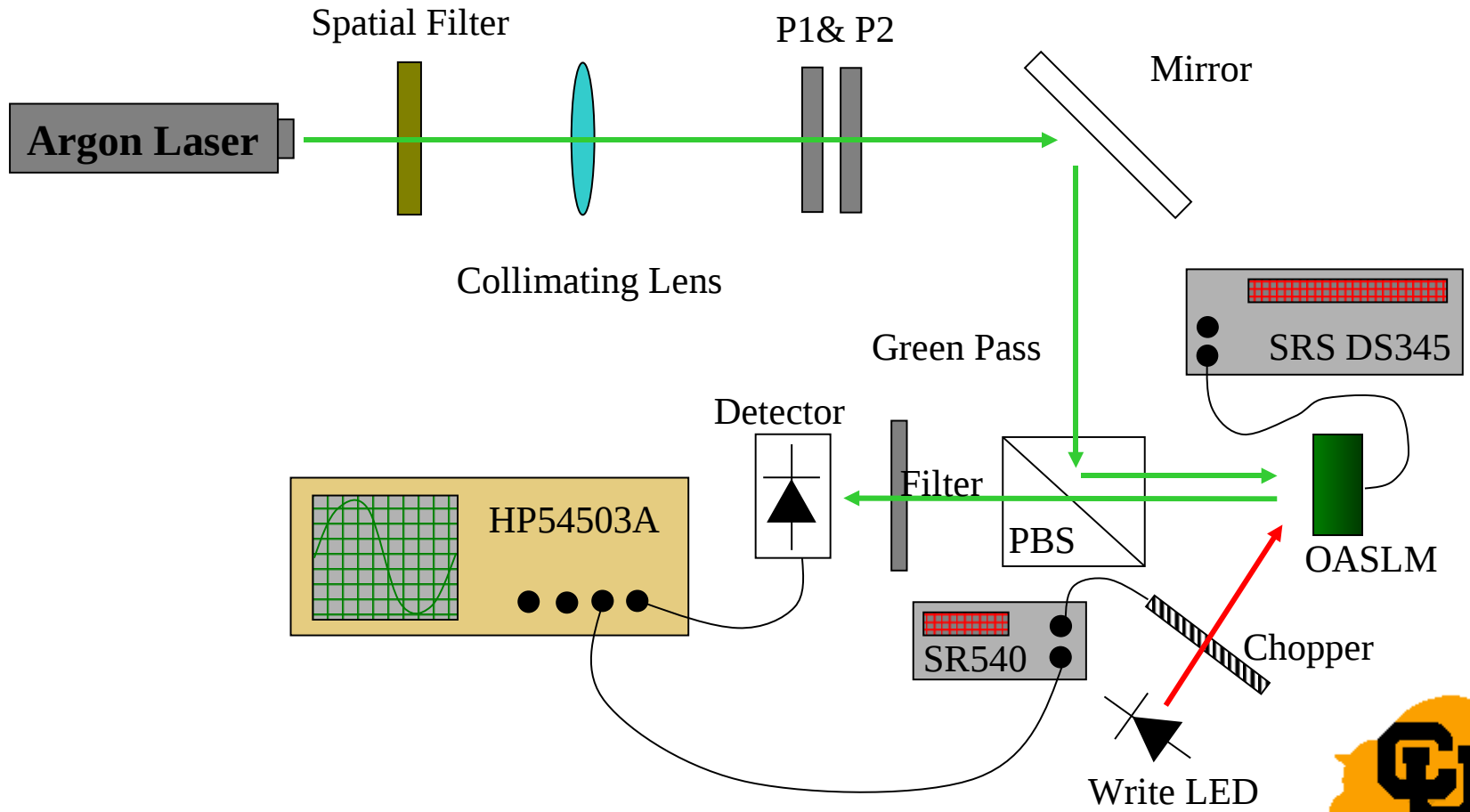

It Works !

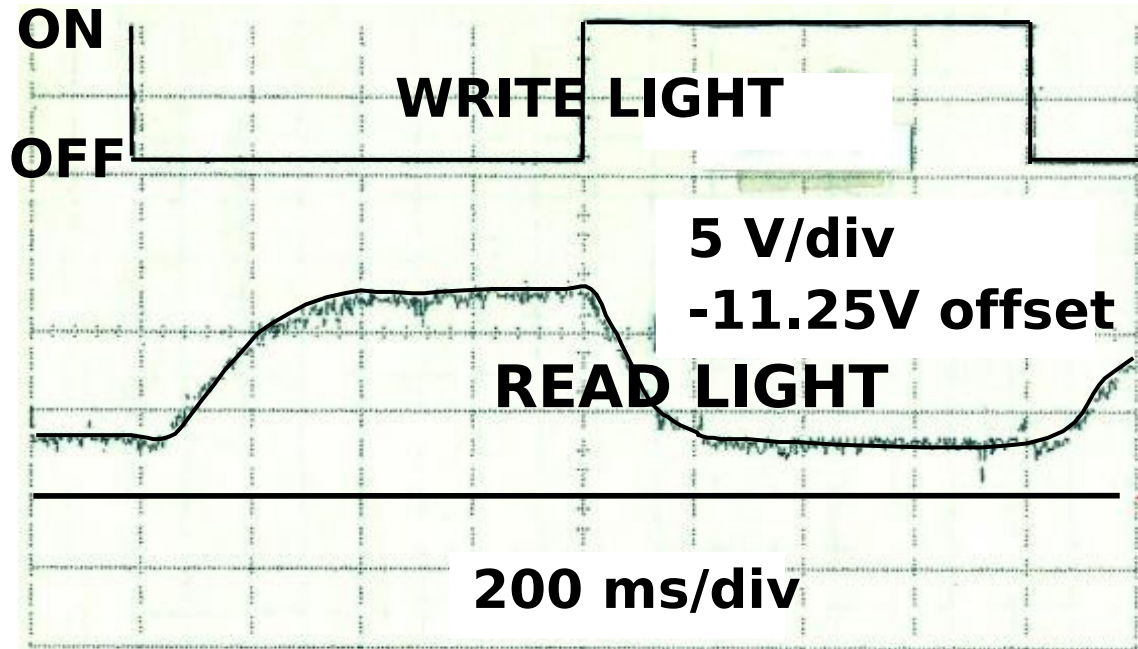

- Small area OASLM (mm diameter)
- Fabricated on soda-lime glass (not optically flat)
- Verify OASLM is operational
- Must be fabricated on optical flats for resolution etc.

Conclusions

- Fabricated an a-Si:H/CIGS Heterojunction
- operational small area IR-OASLM
- Future : construct OASLM on optical flats
 - uniform gapping of liquid crystal
 - fully evaluate performance (resolution, MTF, sensitivity etc.)